

# C60-TUBE-133C-M

THIS DRAWING AND ALL DATA INCLUDED IS THE PROPERTY OF APPLIED SCIENTIFIC INSTRUMENTATION AND THE INFORMATION CONTAINED HEREIN IS FOR GENERAL PRESENTATION PURPOSES ONLY AND MAY CHANGE AT ANY TIME. CONTACT ASI OR A FACTORY REPRESENTATIVE FOR PROJECT SPECIFIC ENGINEERING.

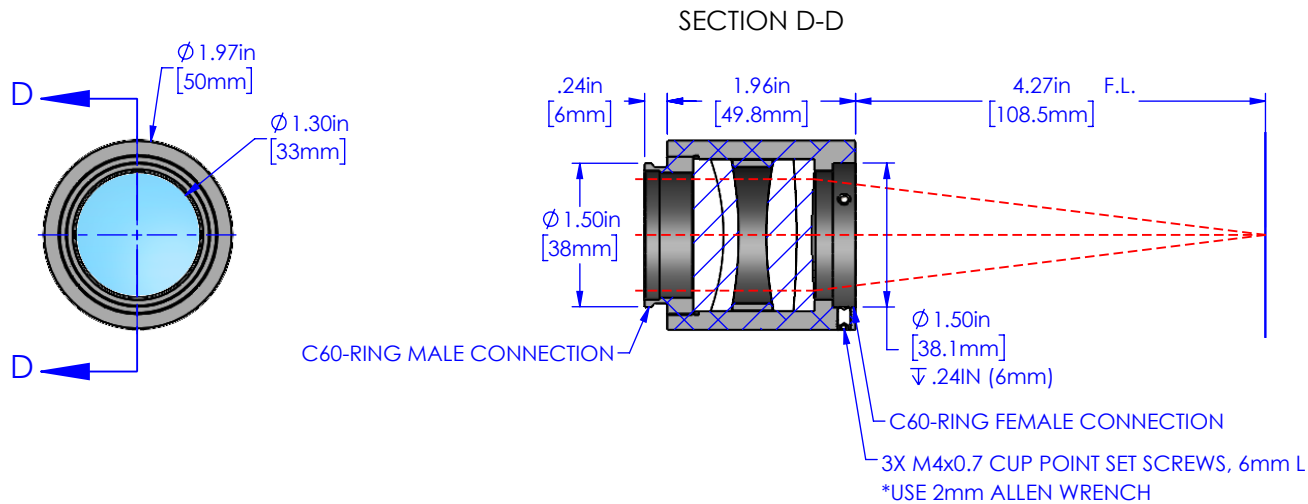

**PROPRIETARY AND CONFIDENTIAL**  
 THE INFORMATION CONTAINED IN THIS DRAWING IS THE SOLE PROPERTY OF APPLIED SCIENTIFIC INSTRUMENTATION. ANY REPRODUCTION IN PART OR AS A WHOLE WITHOUT THE WRITTEN PERMISSION OF APPLIED SCIENTIFIC INSTRUMENTATION IS PROHIBITED.

APPLIED SCIENTIFIC INSTRUMENTATION  
 29391 W ENID RD  
 EUGENE, OR 97402-9533  
 PHONE: (541)461-8181  
 FAX: (541)461-4018

UNLESS OTHERWISE SPECIFIED  
 DIMENSIONS ARE IN INCHES  
 .xx ± .01  
 .xxx ± .005  
 .xxxx ± .0002  
 FRACTIONS ± 1/32  
 ANGLES ± 1°

**DESCRIPTION**

MODULAR TUBE LENS

**DRAWN BY/DATE**

M.ANTHONY 9/19/23

**CHECKED BY/DATE**

V.MARSO 9/19/23

**SCALE**

1:2

**REV**

-

**MATERIAL**

ALUM, ANODIZED BLK

**DRAWING #**

C60-TUBE-133C-M